



### General Description

The PULNiX TM-6710 is a high resolution monochrome camera with non-interlace quad speed scanning, 120 Hz format and partial scanning (200 and 100 lines) capabilities. Since the quad speed mode is standard, images can be displayed on a multi-sync monitor. PULNiX PVM multi-sync monitors can display all functions including partial scanning.

The signal is analog progressive scanning (484 lines). The full frame electronic shutter with asynchronous reset permits shutter speeds to 1/32,000 sec. The shutter function works in all scanning modes. Square pixels provide excellent image definition in all orientations.

Optional features include AGC enable, internal IR cut filter, gamma adjust to 0.45, and remoted imagers.

### Applications

- Motion analysis
- High speed on-line inspection
- Gauging
- Character reading
- High definition graphics
- Fast speed surveillance

### LVDS Communication

A key feature of the TM-6710 is LDVS (Low Voltage Differential Signaling) communication. Due to the low voltage swing, this state of the art technology reduces the amount of noise at high data transmission rates. Because the TM-6710 scans at a very fast 120 Hz, LVDS communication is essential in order to successfully transfer images.

### Product Features

- High resolution 1/2" progressive scanning interline transfer CCD imager 648(H) x 484(V)
- Quad speed progressive scan (510 lines at 120 Hz, 60 Hz) or partial scan at up to 350 Hz
- Full frame shutter, 1/60 to 1/32,000 sec.
- Asynchronous reset with external shutter control
- 8-bit x 2 (or 8-bit x 1) RS-644 digital output and up to 120 Hz analog output
- RS-232 (or RS-485) Control for gain, A/D ref., shutter and mode selection with Win98/NT compatible software
- AGC on/off, gamma 1.0 or 0.45 (AGC off, gamma 1.0 standard)
- On chip micro-lens and low smear at fast shutter

### Asynchronous Reset

The TM-6710's asynchronous reset is flexible and takes external horizontal drive (HD) for phase locking (External HD = HD Output/2). When EVINIT pulse is applied, it resets the camera's scanning and purges the CCD.

Three modes control the asynchronous reset and shutter speed. With Async shutter mode and external VINIT high (5V), the async mode is automatically selected and the signal readout is inhibited until the trigger pulse occurs. Without EVINIT trigger, the output is black video.

**1. External VINIT with controlled pulse width.** The duration between pulse edges (5 volt TTL level) controls the shutter speed and integration period externally.

**2. Internal shutter speed with Fast mode.** The video signal capturing has no delay from the reset timing if the falling edges of EVINIT and external HD are the same. Otherwise, there is a 0-1 HD delay before vertical scan resets.

**3. Internal shutter speed with Slow mode.** The shutter speed control can be selected from 1/250 to 1/2,000 sec. Since the exposure period is longer than the frame period, the data transfer is delayed to accommodate exposure.

### Integration

The CCD imager of the TM-6710 can be exposed longer than normal TV timing (1/60 sec.). This feature provides high sensitivity for dark environment applications. Integration is achieved by controlling the pulse width of EVINIT input up to a few seconds. The progressive scanning CCD chip in the TM-6710 produces a full frame of resolution, using a frame grabber to capture the one frame of integrated image in non-interlace format.

# Electronic Shutter

The TM-6710 has a substrate drain type shutter mechanism which produces a superb picture at various speeds without smearing. The built-in manual shutter speed control selects the electronic shutter rate of 1/125, 1/250, 1/500, 1/1,000, 1/2,000, 1/4,000, 1/8,000, 1/16,000, or 1/32,000 sec. All shutter speeds are applied to partial scan, except slow speed at partial scanning. Progressive scanning allows a full 484 lines of vertical resolution per single shutter, unlike a conventional CCD camera at only 244 lines per shutter.

## Partial Scanning

By setting the mode switch on the back plate and sending the RS-232 command, the TM-6710 can have partial scanning of 200 and 100 lines (full resolution at narrower field of view and faster frame rate).

	Switch selection		
Normal mode:	F	UP	120 Hz progressive scan
200 line scan:	F	DWN	240 Hz progressive scan
100 line scan:	E	UP	350 Hz progressive scan

(Special option: 2-row binning at 240 lines, 240 Hz)

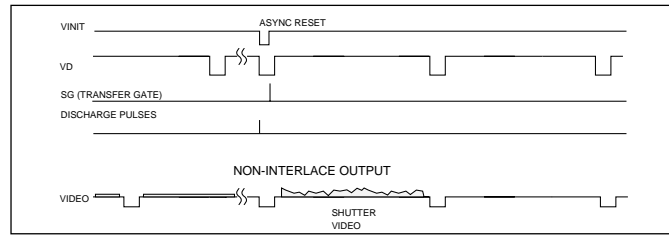

## Shutter Control Switch

Manual Shutter		Async Reset	
0	no shutter	1/120	normal 1/120
1	1/250	128H	1H 1/32,000
2	1/500	64H	2H 1/16,000
3	1/1,000	32H	3H 1/12,000
4	1/2,000	16H	4H 1/8,000
5	1/4,000	8H	8H 1/4,000
6	1/8,000	4H	16H 1/2,000
7	1/12,000	3H	32H 1/1,000
8	1/16,000	2H	64H 1/500
9	1/32,000	1H	Shutter determined by pulse width (P.W.C.)

*Async Reset Mode: Mode 0: normal mode; Mode 1-4: fast mode; Mode 5-8: slow mode; Mode 9: pulse width mode. At modes 1-9 the camera is at standby only, black video is output. One frame image will be output upon receiving an async reset pulse.*

# Mode Control Switches

## Mode Control Switch

- 0 Normal mode
- 1 Gain control (A/B)
- 2 Gain (A/B) fine tune
- 3 ChA Vref control
- 4 ChB Vref control
- 5 Gain selection
- 6 Gain selection
- 7 Clock selection
- 8 Async / Manual shutter
- 9 Factory set recall
- A Power up (recall or save)
- B-C User page storage (store user settings)
- D Direct Shutter
- E Partial scan
- F Partial scan

## Up/Down Switch

- up/down - increase/decrease gain of Ch. A & Ch. B
- up/down - increase/decrease gain of Ch. A, while decrease/increase gain of Ch. B, at 5:1 ratio
- up/down - increase/decrease A/D voltage reference of Ch. A
- up/down - increase/decrease A/D voltage reference of Ch. B
- up: 9dB                      down: 12dB
- up: 18dB                     down: 22dB
- up: 120Hz                    down: 60Hz (input sync changed automatically)
- up: Manual                    down: Async
- up/down: recall only
- up: recall                      down: save
- up: recall                      down: save
- up/down - increase/decrease manual shutter speed
- up: 100 lines                down: normal scan (or binning)
- up: normal scan             down: 200 lines

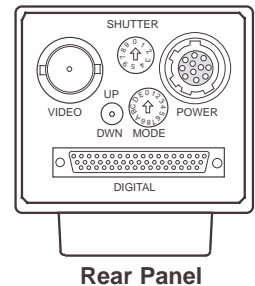

# External Synchronization

The TM-6710 can accept external HD and VD for phase locking. The internal PLL will accept external HD and lock with the CCD's horizontal drive (HD). The CCD HD frequency is half of the analog video output HD.

**Example:** Ext. HD = 30.49 kHz; VD will be 120 Hz and Master Clock will be 50.90 mHz.

The internal sync generator will accept external VD to generate internal VD. The external VD frequency should be ±5% of the frame rate.

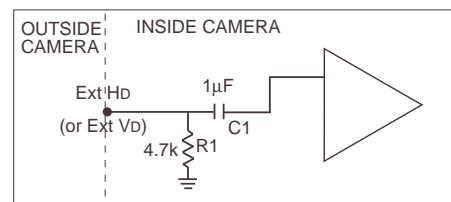

## External Sync Input Schematic

$$\text{Ext. HD} = \frac{\text{HD Output Frequency}}{2} \text{ Frequency.}$$

# Pin Configuration

## 12-Pin Connector

1	GND	7	VD in
2	12V in	8	N/C
3	GND	9	HD in
4	Video out	10	RXD
5	GND	11	INTEG
6	Evinit	12	TXD

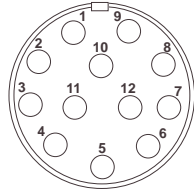

12-Pin Connector

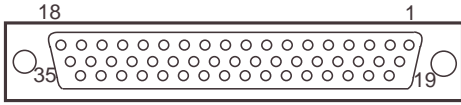

51-Pin Connector

## 51-Pin Connector

Pin#	Description	Pin#	Description	Pin#	Description
1	AO+	18	CLK+	35	CLK-
2	BO+	19	A0-	36	GND
3	A1+	20	B0-	37	VCC
4	B1+	21	A1-	38	VCC
5	A2+	22	B1-	39	EXT. HD
6	B2+	23	A2-	40	TXA0
7	A3+	24	B2-	41	LPULSE
8	B3+	25	A3-	42	RXA0
9	A4+	26	B3-	43	EVINIT
10	B4+	27	A4-	44	INTEG
11	A5+	28	B4-	45	EXP-
12	B5+	29	A5-	46	EXP+
13	A6+	30	B5-	47	LDV-
14	B6+	31	A6-	48	LDV+
15	A7+	32	B6-	49	FDV-
16	B7+	33	A7-	50	FDV+
17	GND	34	B7-	51	GND

**Note:** CLK: data clock, LDV: Line data valid, FDV: Frame or field data valid, ENINT: Integration enable, LPULSE: Last pulse. (Note: The "B" channel is used for single channel option). Output is RS-644 standard.

# Specifications

The TM-6710 mode selection can be accomplished remotely via RS-232C/RS-485 control (RS-485 communication control is available as an option). Windows 98 (NT) control software, available from PULNiX, can be used for both RS-232 and RS-485 communications (cable part number pending).

## 12-Pin Male Connector

Pin#	Description
1	GND
2	+12V
3	GND
4	Video Out
5	GND
6	EVINIT
7	VD In
8	N/C
9	HD In
10	N/C
11	INTEG
12	N/C

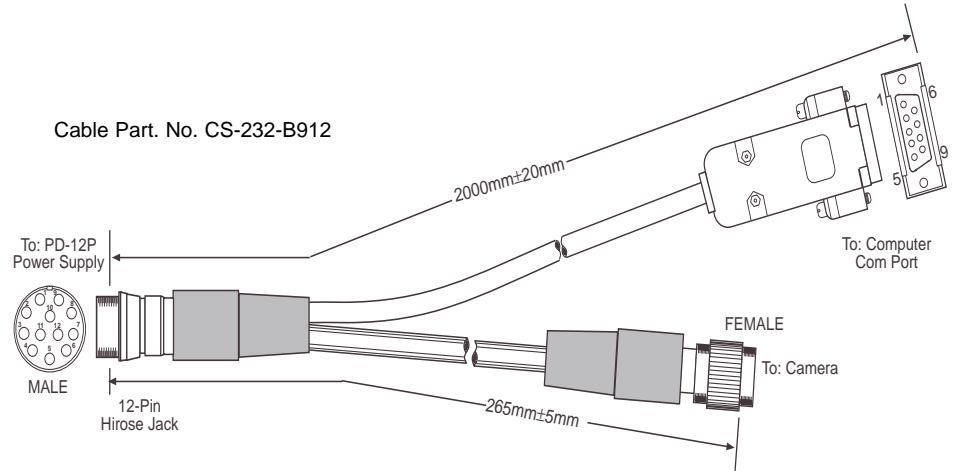

## 12-Pin Female Connector

Pin#	Description
1	GND
2	+12V
3	GND
4	Video Out
5	GND
6	EVINIT
7	VD In
8	N/C
9	HD In
10	RXD
11	INTEG
12	TXD

## D-Sub 9-pin Connector

(ITEM 15-1007)

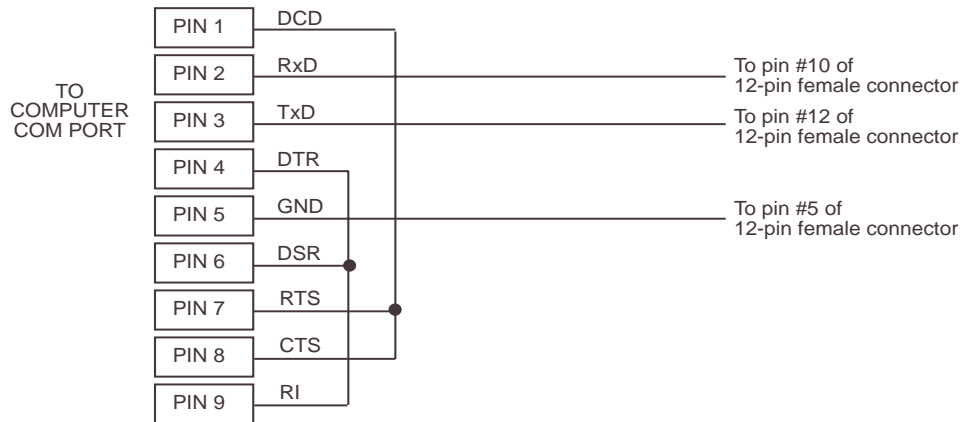

# Specifications

<b>Imager</b>	1/2" progressive scanning interline transfer CCD
<b>Pixels</b>	648 (H) x 484 (V)
<b>Cell size</b>	9.0 $\mu$ m x 9.0 $\mu$ m square pixels
<b>Scanning</b>	120 Hz (quad speed) non-interlace, Partial scanning (200 and 100 lines)
<b>Sync output</b>	HD= 60.98KHz $\pm$ 5%, VD=120Hz $\pm$ 5% (at 50.980MHz) HD=47.94KHz $\pm$ 5%, VD=96Hz $\pm$ 5% (at 40.06MHz:)
<b>External sync input</b>	HD= 30.49KHz $\pm$ 5% (at 50.980MHz)      HD=23.97KHz $\pm$ 5% (at 40.06MHz - optional) Vertical async. reset. or VD=120Hz $\pm$ 5%      Vertical async. reset. or VD=96Hz $\pm$ 5%
<b>Asynchronous reset</b>	Ext. Vinit with pulse width control for shutter and integration
<b>Pixel clock</b>	25.49 MHz (at 50.98MHz) or 20.03 (at 40.06MHz)
<b>TV resolution</b>	500 (H) x 484 (V) lines
<b>S/N ratio</b>	45dB min.( AGC = off )
<b>Min. illumination</b>	4 lux at normal speed (120 frame/sec)
<b>Video output</b>	1.0 Vp-p composite video, 75 $\Omega$ non-interlace
<b>Digital output</b>	2 channel 8-bit, RS-644 standard output
<b>AGC</b>	OFF (AGC ON is a factory option)
<b>Gamma</b>	1.0 (Gamma 0.45 is a factory option)
<b>Electronic shutter</b>	Asynchronous electronic shutter Mode A: 1/32,000 Max. (controlled by 1 H, 2 H, 4 H, ... ) Mode B: External speed control pulse input Full frame resolution per shutter
<b>Lens mount</b>	C-mount
<b>Power req.</b>	12V DC 700 mA
<b>Operating temp.</b>	-10°C to 50°C
<b>Vibration &amp; shock</b>	Vibration: 7Grms, Shock: 70G
<b>Size (W x H x L)</b>	46.1mm x 39.4mm x 140.0mm (1.78" x 1.52" x 5.41")
<b>Weight</b>	260 gr (9.2 oz)
<b>Power cable</b>	12P-02 (not required if camera is used with PD-12P)
<b>Digital Cable</b>	50DG-02LP (contact factory for frame-grabber specific cables) or visit our website at <a href="http://www.pulnix.com">www.pulnix.com</a>
<b>Power supply</b>	PD-12P
<b>RE-232 Cable</b>	CS-232-B912 (use with PD-12P power supply)

# Dimensions

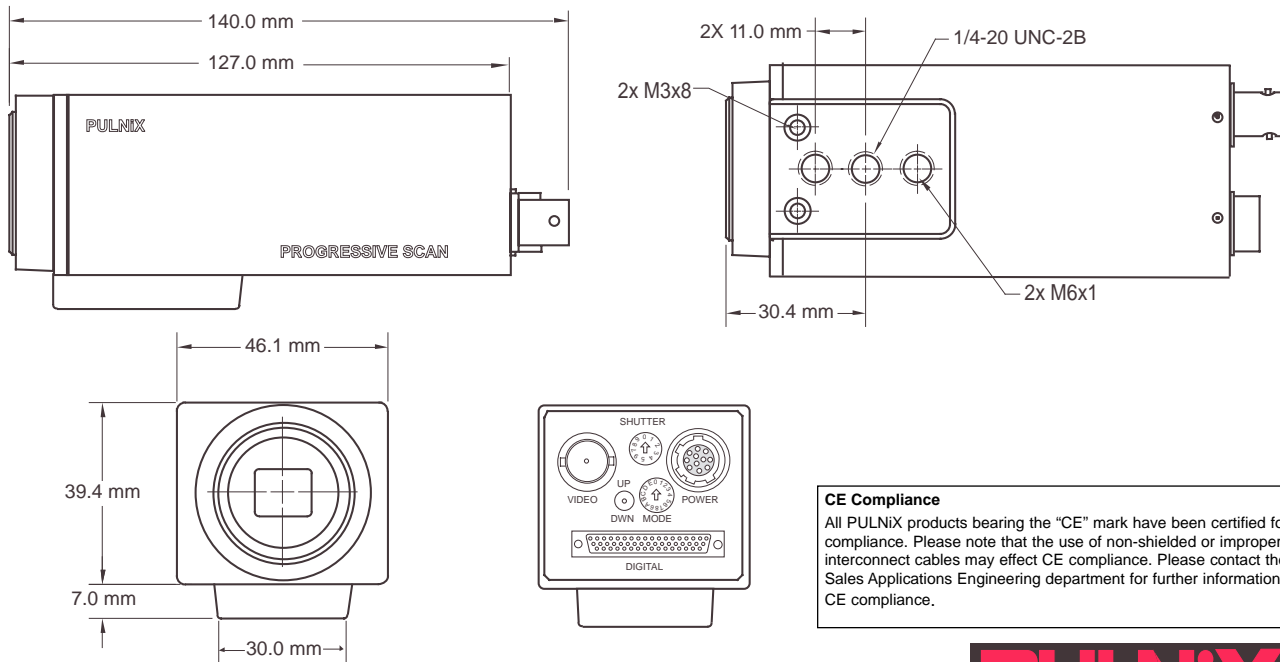

**CE Compliance**  
All PULNiX products bearing the "CE" mark have been certified for CE compliance. Please note that the use of non-shielded or improperly shielded interconnect cables may effect CE compliance. Please contact the PULNiX Sales Applications Engineering department for further information specific to CE compliance.

TM-6710  
71-0026 Rev. A  
Printed: 07/99

**Japan, Tokyo**  
PULNiX America, Inc.  
1-11-14 Hongo  
Bunkyo-ku, Tokyo 113-0033  
Tel: 81-3-5805-2455  
Fax: 81-3-5805-8082  
**Kyoto Office**  
Tel: 81-75-592-2247  
Fax: 81-75-591-2333

**Australia**  
PULNiX America, Inc.  
Unit 16, #35 Garden Road  
Clayton, Vic 3168  
Tel: 3-9546-0222  
Fax: 3-9562-4892

**United Kingdom**  
PULNiX Europe, Ltd.  
Aviary Court, Wade Road  
Basingstoke, Hants RG24 8PE  
Tel: 01256-475555  
Fax: 01256-466268

**Germany**  
PULNiX America, Inc.  
Siemensstrasse 12  
D-63755 Alzenau  
Germany  
Tel: 49(0)6023-9625-0  
Fax: 49(0)6023-9625-11

ISO-9001  
Cert. #A3948VC



**Industrial Products Division**  
PULNiX America, Inc. Tel: 408-747-0300  
1330 Orleans Drive Tel: 800-445-5444  
Sunnyvale, CA 94089 Fax: 408-747-0660  
Email: [pulnix@pulnix.com](mailto:pulnix@pulnix.com)  
[www.pulnix.com](http://www.pulnix.com)